



# User Manual

---

## Spring series LFP Battery

SE-G5.3

---





## About This Manual

The manual mainly describes the product information, guidelines for installation, operation, and maintenance. The manual cannot include complete information about the solar photovoltaic-energy storage hybrid system.

## How to Use This Manual

Read the manual and other related documents before performing any operation on the battery. Documents must be stored carefully and be always available.

**Contents may be updated or modified periodically due to product update iterations. The manual is subject to change without prior notice.** The latest manual can be acquired via service -ess@deye.com.cn (www.deyeess.com).

# 1. Safety Introductions



## Reminding

- 1) It is very important and necessary to read the user manual carefully (in the accessories) before installing or using battery. Failure to do so or to follow any of the instructions or warnings in this document can result in electrical shock, serious injury, or death, or can damage battery, potentially rendering it inoperable.
- 2) If the battery is stored for long time, it is required to charge them every six months, and the SOC should be no less than 50%.
- 3) Battery needs to be recharged within 48 hours after fully discharged.
- 4) Do not expose cable outside.
- 5) All the battery terminals must be disconnected for maintenance.
- 6) Please contact the supplier within 24 hours if there is something abnormal.
- 7) Do not use cleaning solvents to clean battery.
- 8) Do not expose battery to flammable or harsh chemicals or vapors.
- 9) Do not paint any part of Battery, include any internal or external components.
- 10) Do not connect battery with PV solar wiring directly.
- 11) The warranty claims are excluded for direct or indirect damage due to above items.
- 12) Any foreign object is prohibited to insert into any part of battery.



**Li-ion**





## Warning

### 1.1 Before Connecting

- 1) After unpacking, please check product and packing list first, if product is damaged or lack of parts, please contact with the local retailer.
- 2) Before installation, be sure to cut off the grid power and make sure the battery is in the turned-off mode.
- 3) Wiring must be correct, do not mistake the positive and negative cables, and ensure no short circuit with the external device.
- 4) It is prohibited to connect the battery and AC power directly.
- 5) Battery system must be well grounded and the resistance must be less than  $1\Omega$ .
- 6) Please ensured the electrical parameters of battery system are compatible to related equipment.
- 7) Keep the battery away from water and fire.

### 1.2 In Using

- ✧ If the battery system needs to be moved or repaired, the power must be cut off and the battery is completely shut down.
- ✧ It is prohibited to connect the battery with different type of Battery.
- ✧ It is prohibited to put the batteries working with faulty or incompatible inverter.
- ✧ It is prohibited to disassemble the battery.
- ✧ In case of fire, only dry fire extinguishers can be used. Liquid fire extinguishers are forbidden.
- ✧ Please do not open, repair, or disassemble the battery except staffs from DEYE or authorized by DEYE. We do not undertake any consequences or related responsibility which because of violation of safety operation or violating of design, production, and equipment safety standards.

## 2. Product Introduction

- ✧ This lithium iron phosphate battery is one of new energy storage products developed and produced by DEYE, it can be used to support reliable power for various types of equipment and systems.
- ✧ This battery is especially suitable for application scene of high power, limited installation space and long cycle life.
- ✧ This battery has built-in BMS battery management system, which can manage and monitor cells information including voltage, current and temperature. What's more, BMS can balance cells charging and discharging to extend cycle life.
- ✧ Multiple batteries can connect in parallel for larger capacity and longer power supporting duration requirements

### 2.1 Front Panel Function Introduction

In order to operate the product correctly, please carefully view the function of the front panel of the battery.

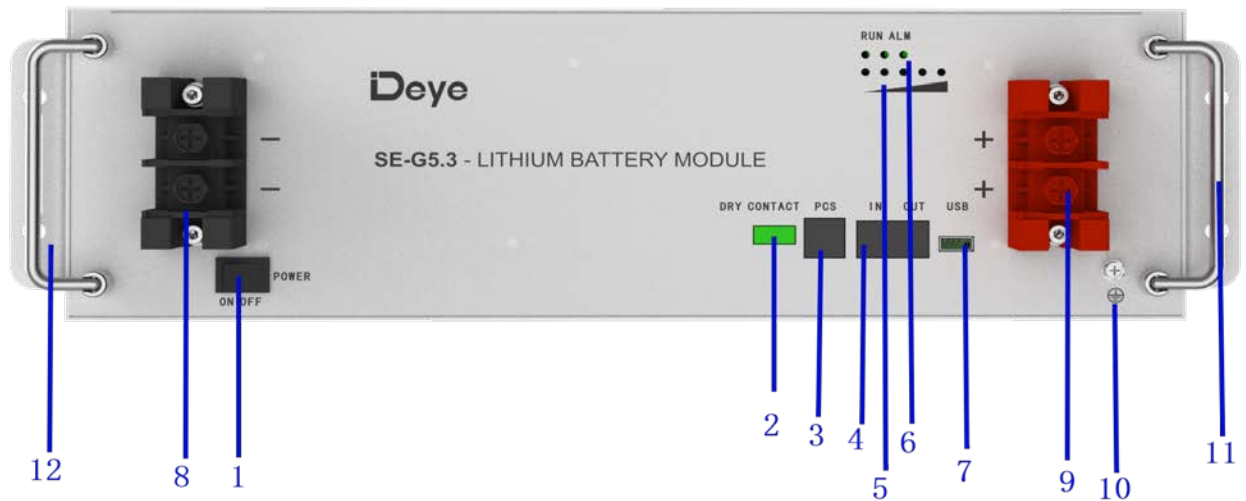

Figure 2-1: Front Panel Function Introduction

1. Power button: to turn ON/OFF the whole battery BMS standby, no power output.
2. DRY CONTACT output.
3. PCS: Inverter communication terminal: (RJ45 port) follow the CAN protocol (baud rate: 500kbps), and RS-485(baud rate: 9600bps), used to output battery information to the inverter.
4. IN: parallel Communication Terminal: (RJ45 port) Connect "out" Terminal of Previous battery, for communication between multiple parallel batteries.
5. SOC: These 5 LEDs are used to display the pack SOC. The lighting of these LEDs indicates the SOC of 20%, 40%, 60%,80% and 100%.
6. RUN light: green LED lighting to show the battery running status  
Alarm light: yellow and red LED lighting to show the battery has been alarmed or protected.
7. OUT: parallel Communication Terminal: (RJ45 port) Connect "IN" Terminal of Next battery, for communication between multiple parallel batteries.
8. USB: (USB port) Used to insert USB flash drive for battery upgrade.
9. Negative output terminal.
10. Grounding bolt.
11. Handle: It was used to carry/move the battery.
12. Positive output terminal.
13. Used for fixing with cabinet.

## 2.2 Communication Port

### (1) PCS Port Definition

Definition of PCS Port Pin

No.	PCS Port Pin
1	485-B
2	485-A
3	-
4	CANH
5	CANL
6	-
7	485-A
8	485-B



### (2) IN Port Definition

Definition of IN Port Pin

No.	PCS Port Pin
1	CANL
2	CANH
3	DI+
4	DI-
5	DI-
6	DI+
7	CANH
8	CANL



### (3) OUT Port Definition

Definition of Out Port Pin

No.	Out Port Pin
1	CANL
2	CANH
3	DO+
4	DO-
5	DO-
6	DO+
7	CANH
8	CANL



## 2.3 Product Specifications

Table 2-1: Product Specifications

Main Parameter		SE-G5.3
Battery Chemistry		LiFePO <sub>4</sub>
Capacity (Ah)		104
Scalability		Max. 64 pcs pack (340kWh) in parallel (Max. 32 pcs no external setup)
Nominal Voltage (V)		51.2
Operating Voltage(V)		43.2~57.6
Energy (kWh)		5.32
Usable Energy (kWh) <sup>[1]</sup>		4.79
Charge/Discharge Current (A) <sup>[2]</sup>	Recommend	50
	Max.	100
	Peak	150 (2mins,25°C)
Other Parameter		
Recommend Depth of Discharge		90%
Dimension (W/H/D, mm)		440*133*560
Weight Approximate(kg)		44
Master LED indicator		5LED(SOC:20%~100%)
		3LED (working, alarming, protecting)
IP Rating of enclosure		IP20
Working Temperature		Charge:0°C~55°C Discharge:-20°C~55°C
Storage Temperature		0°C~35°C
Humidity		5%~95%
Altitude		≤2000m
Cycle Life		≥6000(25°C±2°C,0.3C/0.3C 90%DOD,70%EOL)
Installation		19-inch standard rack (depth≥600mm), Floor-Mounted
Communication Port		CAN2.0, RS485
Certification		CE, IEC62619, UN38.3
Energy Throughput		16MWh@70%EOL

[1] DC Usable Energy, test conditions: 90% DOD, 0.3C charge & discharge at 25°C. System usable energy may vary due to system configuration parameters.

[2] The current is affected by temperature and SOC.

## 2.4 State Indicator

Condition	RUN	ALM	ERROR	SOC1	SOC2	SOC3	SOC4	SOC5	
Power Off	Off								
Discharge or Idle	Blink	Blink if Alarm Exists	Off	e.g., Soc67%:					
			Off	On	On	On	On		
Charge		Blink	Blink	Off	e.g., Soc47%:				
				Off	Off	Blink	On	On	
Alarm			Off	Same as 'Discharge or Idle'					
System Error/Protection			On						
Upgrade	Blink Fastly								
Critical Error	Blink Slowly								

# 3. Unpack the Battery

The battery and the related accessories are packed in the carton box. Use tools to open the packing box. After open the packing box, confirm the product components according to the parts list.



## Warning

**Violent unpacking is strictly prohibited. If the battery system is found to be broken, deformed or other abnormal conditions, the user shall immediately stop using the battery and contact us.**

## 3.1 Parts List

Check the parts during unpacking.

Table 3-1: Parts List

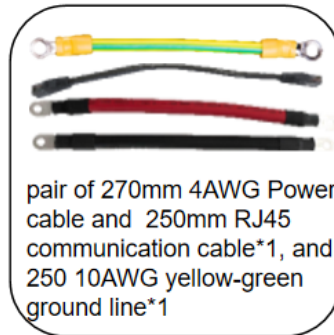
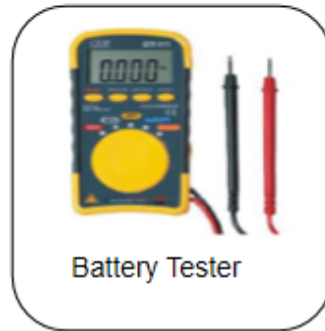



Table 3-2: Recommended Tools and Instruments



### 3.2 Visual Inspection of the Modules

After transporting the modules to the installation location, check for:

- Physical damage to the exterior.
- Damaged or protruding screws.

## 4. Battery Installation

This system must be installed by qualified, trained workers familiar with the required instruments.



### Warning

- Be sure to use insulated tools (torque wrench, extension, socket, etc.).
- All the instruments must be insulated and no metal articles (e.g., watch, ring) should be present in the installation area.
- All power switches must be turned off in advance.
- Prepare a CO<sub>2</sub> fire extinguisher, a first aid kit, and an AED (automated external defibrillator) before installation.
- Arc Flash and Shock Hazard: Insulated tools are required for any work on this energized equipment.
- Sharp Edges: Wear gloves and other protective gear to prevent injury.
- Pinch Point: Use caution when working in the enclosure to prevent injury.
- Heavy Object: Can cause muscle strain or back injury. Use lifting aids and proper lifting techniques when moving trays, batteries, and other heavy objects.

## 4.1 General requirements for installation

- (1) Transport battery modules to the installation location.
- (2) Place the battery modules on the bracket or rack or cabinet.
- (3) Fix the battery on the bracket or rack. Using the bracket or cabinet bolt to fix the battery into the bracket or rack.
- (4) After installation, tighten all bolts.

## 4.2 Installation method 1:

With simple bracket installation



## 4.3 Installation method 2:

With standard 19 inches cabinet or rack installation



### 4.4 Installation method 3:

#### Wall-mounted method

The installation location description should meet the size requirements of the figure below:

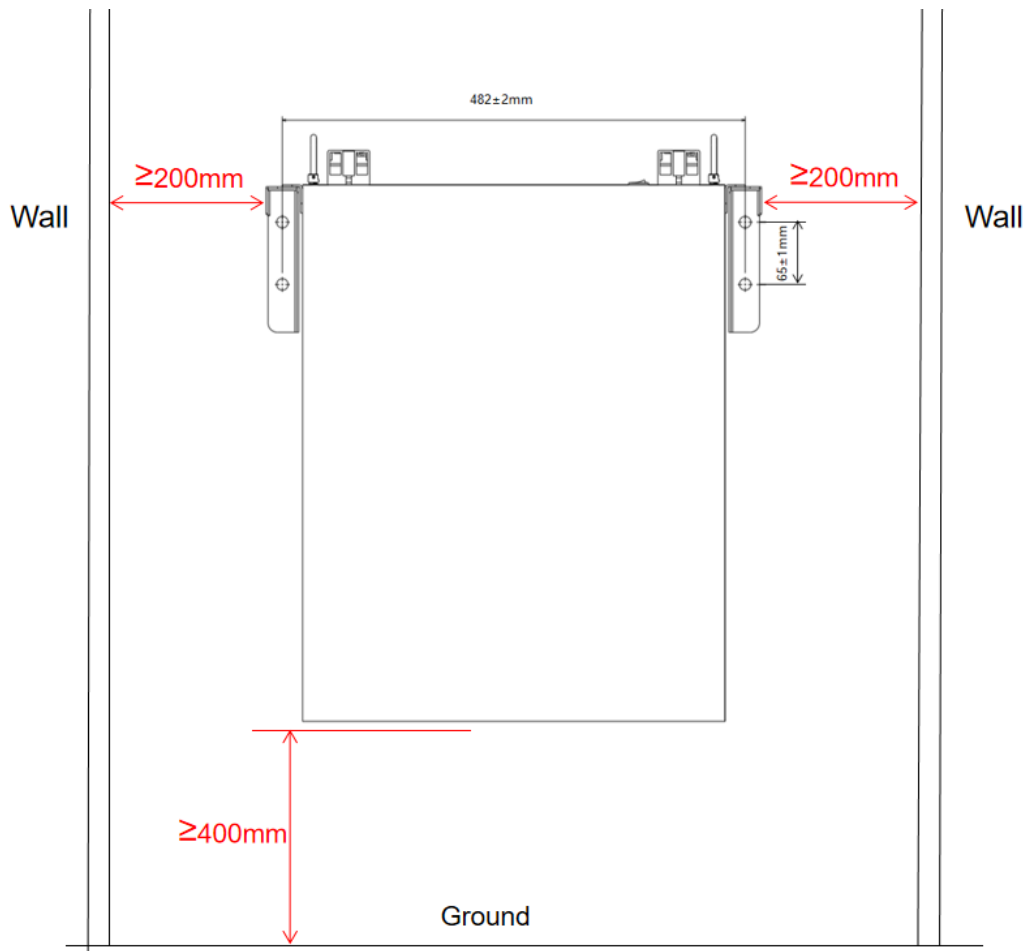

Figure 4-1

a) Use the 6 screws of M4\*8 to fix the battery pack Fixed Ears the both sides battery, as show in Figure 4-2.



M4\*8 screws

Use the 6 screws of M4\*8 to fix the battery pack Fixed Ears the battery both end.

Figure 4-2

- b) Choose the recommend drill head (as shown in Figure 4-3) to drill 4 holes on the wall,100mm-110mm deep.
- c) Use a hammer to secure the support to the wall, and install the expansion bolt in the hole, as shown in Figure 4-3.

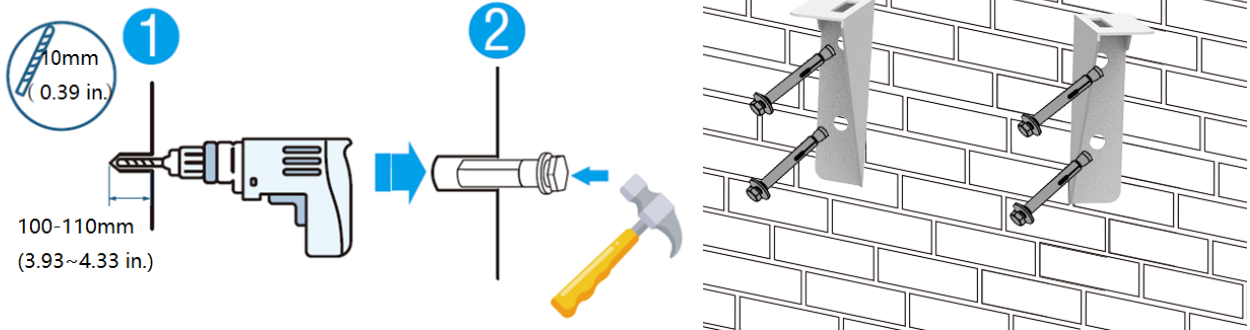

Figure 4-3

- d) Fasten the screw head of the expansion bolt to finish the mounting.
- e) Carry the battery and hold it. Fix the battery to the support after fixing it to the wall. Ensure that battery mounting ears are aligned with the left and right holes on the support, as shown in Figure 4-4.



4 sets of screws and buckle nuts(left side and right side)



Figure 4-4

- The battery can be mounted on a standard 19 inches cabinet or rack.
- Battery modules can be inserted into a rack frame according to the customer battery configuration scheme.



### Warning

Note the allowable installation modes.

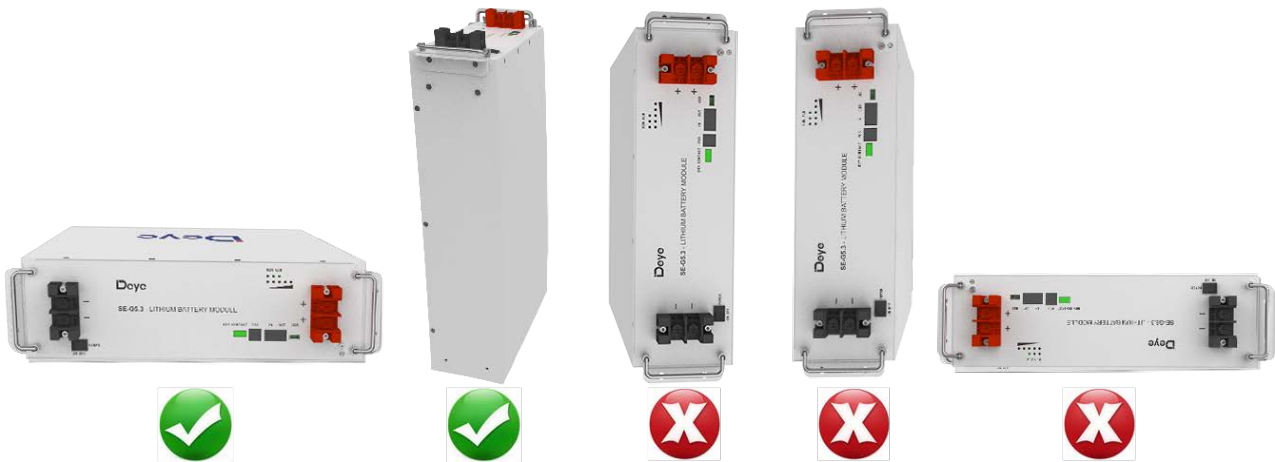

## 5. Cable Connection

### 5.1 Single Battery Connection



### Warning

- Before connect the cable with the inverter, the worker must confirm the output switch of the inverter has been turn off, to prevent the risk of fire or electric shock.
- Before connection, make sure to close the battery.
- Please follow the instructions to protect the module BMS against damage.
- DO NOT deviate from the sequence of steps below.
- Exercise extreme caution prevent the terminals from contacting anything except their intended mounting points.
- Terminals and their connected wires have either positive or negative polarity (Positive: +; Negative-). The polarity of a terminal or a wire connected to the terminal is on the front of each module. Exercise extreme caution to prevent the terminals and/or wires with opposite polarity from contacting with each other.

- The maximum voltage of the battery is no more than 60V, which is higher than the safe voltage of 36V. Therefore, we still recommend that the battery terminals or other exposed parts should not be directly touched during the installation.
- When tightening the screws, make sure they are at a straight angle from the battery module terminals to avoid damage to the nuts inside.
- The power terminals, such as “+,” “-,” of the module are covered with the protecting cover to guard against a short circuit (Shown in Figure 5-1).
- You must remove the insulation cover prior to connecting.

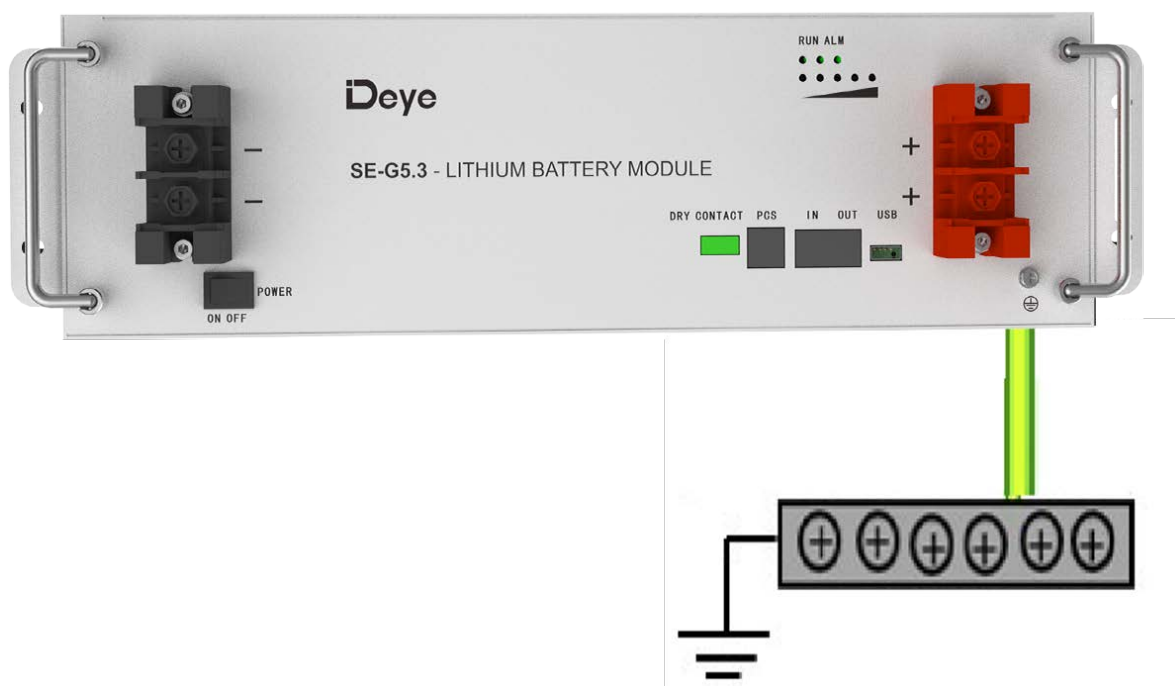

Figure 5-1: Install the Grounding Wire  
(Using a Phillips-head within the fastening torque of less than 3.0 N.m)

Step 1: Wear the protective gloves.

Step 2: Install the battery ground cable.

Step 3: Install negative and positive power cables for the battery.

- 1) Remove the protective cover from the battery power wiring terminal.
- 2) Connect the negative power cable to the battery.
- 3) Connect the positive power cable to the battery.
- 4) Install the other end of the battery power cables at a battery route and the corresponding busbar in the power system.

**Connect the inverter:**

- 1) Remove the protecting cover.
- 2) Connect the positive output cable between the battery positive terminal of the battery and the inverter. The plug must be firmly inserted to ensure a reliable connection.
- 3) Connect the negative output cable between the battery negative terminal of the battery and the inverter. The plug must be firmly inserted to ensure a reliable connection.
- 4) Sort the cables and fasten the battery cables to the perforated bracket with cable ties.
- 5) Communication line connection as shown in Figure 5-2.

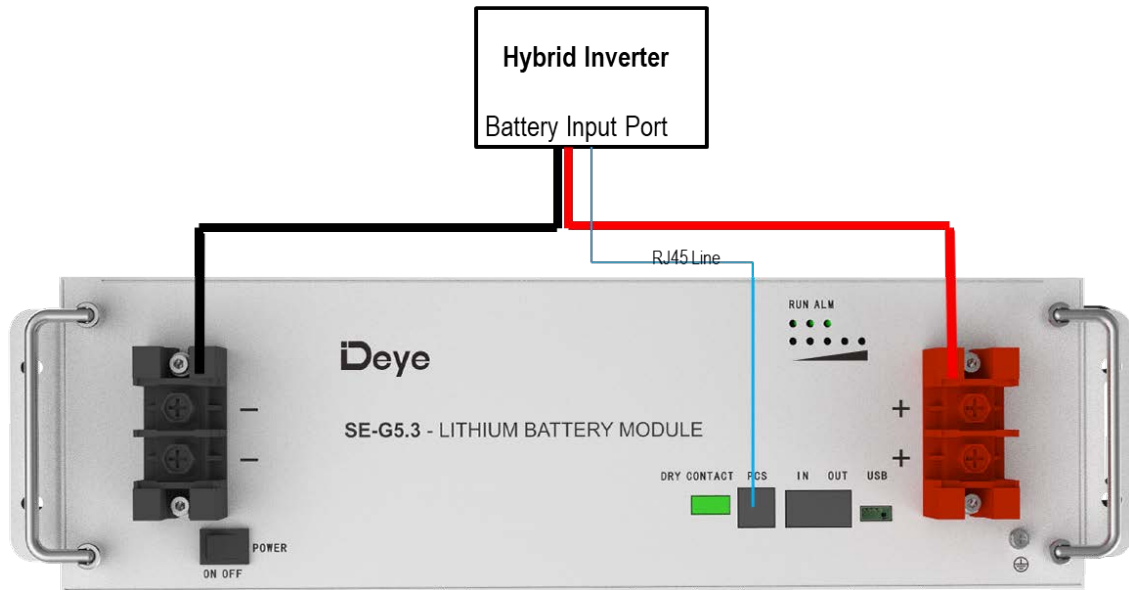

Figure 5-2: Single Battery Connection

- 6) If you need to debug the battery, connect the communication line between battery and computer with USB converter (USB to RS485 or CAN2.0).

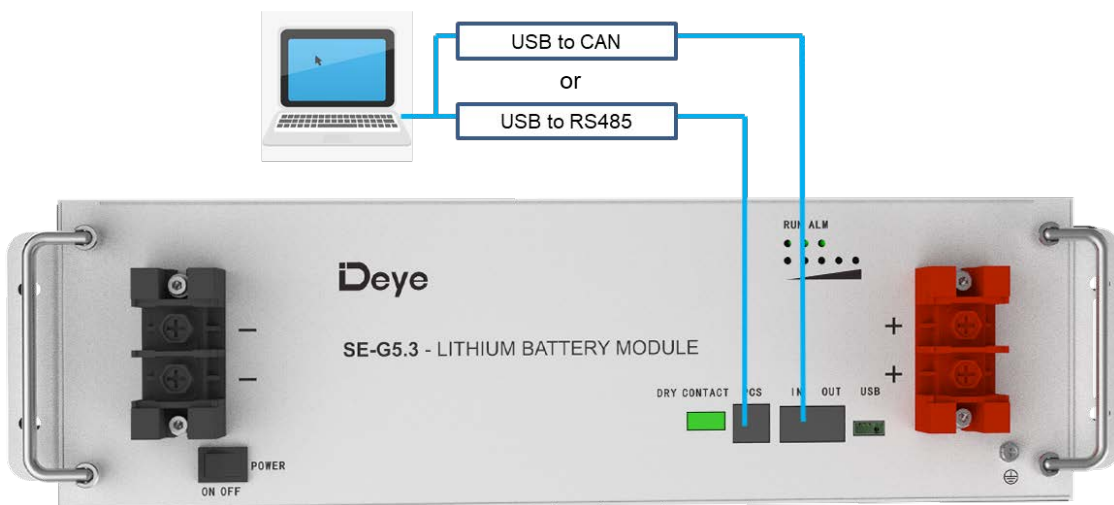

Figure 5-3: Communication Connections between Battery and Computer

## 5.2 Multiple Batteries in Parallel

When multiple batteries in parallel, the cable connecting procedures are follows.

5.2.1. As shown in Figure 5-4, following the cable connection method of the single battery, connect the positive and negative cables between the Battery 1 and the busbar, Battery 2 and the busbar, and Battery N and the busbar respectively.

**Note:** To ensure the current balance, please use cables with the same diameter and length for each battery.

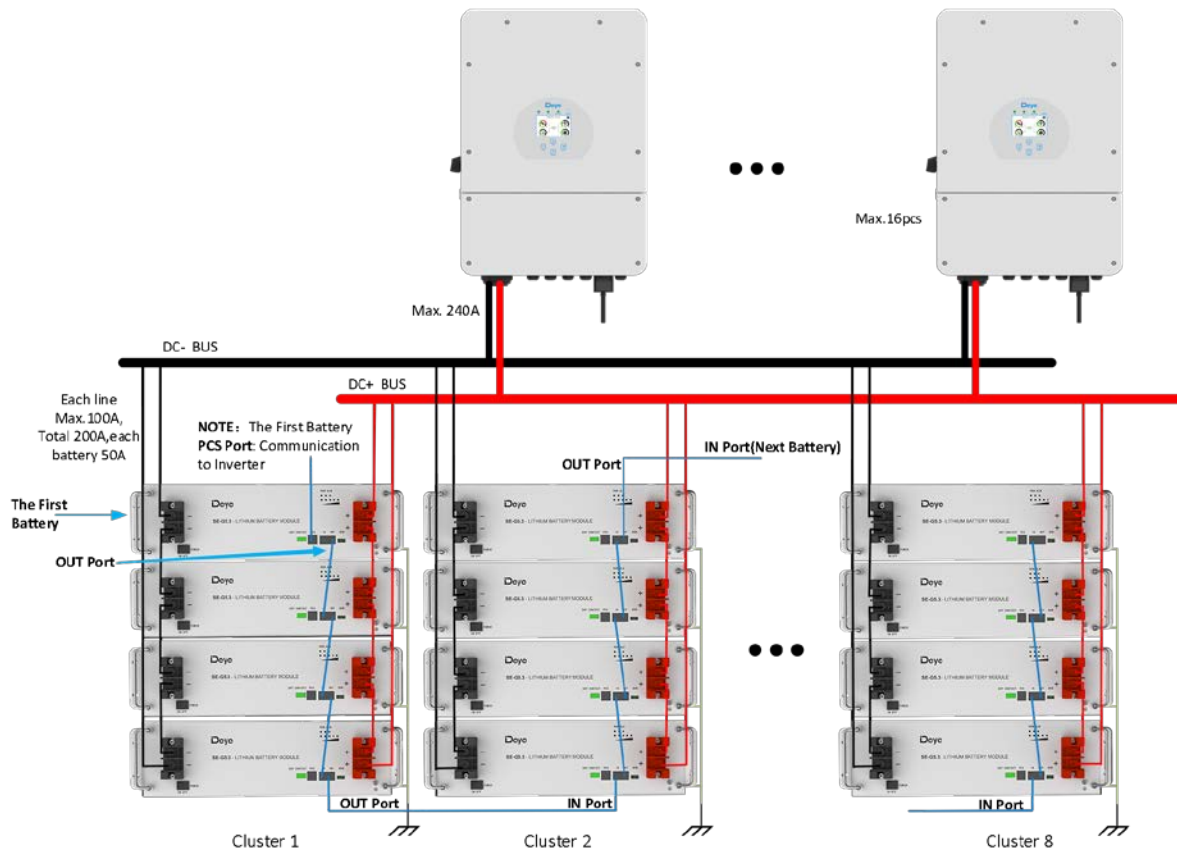

Figure 5-4: Multiple Batteries Connections

5.2.2. As shown in Figure 5-4, connect the communication line (a standard RJ45 network cable) between the adjacent batteries.

**Note:** The **PCS Port** of the first battery must be connected to the inverter's battery communication interface, otherwise the inverter cannot communicate with the batteries.

**Note:** The **OUT Port** of the first battery is connected to the **IN Port** of the next battery, and so on, connecting the communication of multiple batteries together, otherwise multiple batteries will not be able to communicate correctly.



## 5.3 Visual Inspection of the Connection

After connecting the battery, check for:

- Usage of positive and negative cables.
- Connection of the positive and negative terminals. Terminals must be securely inserted to ensure reliability
- All the bolts are tightened.
- Cables fixation and the appearance.
- The communication cable is connected correctly.
- The installation of the protecting cover.

## 6. Activate the Product

### 6.1 Start the Battery

After installation, wiring, and configuration are completed, you must check all the connection. When the connections are correctly, and then press power button to activate the battery. The green working light on the front panel of the battery flashes, indicating that the battery system is normal.

## 7. Inspection, Cleaning and Maintenance

### 7.1 General Information

- The battery product is not fully charged. It is recommended that the installation be completed within 3 months after arrival;
- During the maintenance process, do not re-install the battery in the battery product. Otherwise, the performance of the battery will be reduced;
- It is forbidden to dismantle any battery in the battery product, and it is forbidden to dissect the battery;
- After the battery product is over-discharged, it is recommended to charge the battery within 48 hours. The battery product can also be charged in parallel. After the battery product is connected in parallel, the charger only needs to connect the output port of any product battery.
- Never attempt to open or dismantle the battery! The inside of the battery does not contain serviceable parts.
- Disconnect the Li-Ion battery from all loads and charging devices before performing cleaning and maintenance activities
- Place the enclosed protective caps over the terminals before cleaning and maintenance activities to avoid the risk of contacting the terminals.

## 7.2 Inspection

- Inspect for loose and/or damaged wiring and contacts, cracks, deformations, leakage, or damage of any other kind. If damage to the battery is found, it must be replaced. Do not attempt to charge or use a damaged battery. Do not touch the liquid from a ruptured battery.
- Regularly check the battery's state of charge. Lithium Iron Phosphate batteries will slowly self-discharge when not in use or whilst in storage.
- Consider replacing the battery with a new one if you note either of the following conditions:
  - - The battery run time drops below 70% of the original run time.
  - - The battery charge time increases significantly.

## 7.3 Cleaning

If necessary, clean the Li-Ion battery with a soft, dry cloth. Never use liquids, solvents, or abrasives to clean the Li-Ion battery.

## 7.4 Maintenance

The Li-Ion battery is maintenance free. Charge the battery to approximately > 80% of its capacity at least once every year to preserve the battery's capacity.

## 7.5 Storage

- The battery product should be stored in a dry, cool, and cool environment.
- Generally, the maximum storage period at room temperature is 6 months. When the battery is stored over 6 months, it is recommended to check the battery voltage. If the voltage is higher than 51.2V, it can continue to store the battery. In addition, it is needed to check the voltage at least once a month until the voltage is lower than 51.2V. When the voltage of the battery is lower than 51.2V, it must to be charged according to the charging strategy.
- The charging strategy is as follows: discharge the battery to the cutoff voltage with  $0.2C_{10}A$  current, and then charge with  $0.2C_{10}A$  current for about 3 hours. Keep the SOC of the battery at 40-70% when stored.
- When the battery product is stored, the source of ignition or high temperature should be avoided and it should be kept away from explosive and flammable areas.

## 8. Troubleshooting

To determine the status of the battery system, users must use additional battery status monitoring software to examine the protection mode. Refer to the installation manual about using the monitoring software. Once the user knows the protection mode, refer to the following sections for solutions.

Table 8-1: Troubleshooting

Fault Type	Fault Generation condition	Possible Causes	Troubleshooting
BMS fault	The cell voltage sampling circuit is faulty. The cell temperature sampling circuit is faulty	The welding point for cell voltage sampling is loose or disconnected. The voltage sampling terminal is disconnected. The fuse in the voltage sampling circuit is blown. The cell temperature sensor has failed.	Replace the battery.
Electrochemical cell fault	The voltage of the cell is low or unbalanced.	Due to large self- discharge, the cell over discharges to below 2.0V after long term storage. The cell is damaged by external factors, and short circuits, pinpricks, or crushing occur.	Replace the battery.
Overvoltage protection	The cell voltage is greater than 3.65 V in charging state. The battery voltage is greater than 58.4 V.	The busbar input voltage exceeds the normal value. Cells are not consistent. The capacity of some cells deteriorates too fast or the internal resistance of some cells is too high.	If the battery cannot be recovered due to protection against abnormality contact local engineers to rectify the fault.
Under voltage protection	The battery voltage is less than 40V. The minimum cell voltage is less than 2.5V	The mains power failure has lasted for a long time. Cells are not consistent. The capacity of some cells deteriorates too fast or the internal resistance of some cells is too high.	Same as above.
Charge or discharge high temperature protection	The maximum cell temperature is greater than 60°C	The battery ambient temperature is too high. There are abnormal heat sources around	Same as above.
Charge low temperature protection	The minimum cell temperature is less than 0°C	The battery ambient temperature is too low.	Same as above.
Discharge low temperature protection	The minimum cell temperature is less than -20°C	The battery ambient temperature is too low.	Same as above.

By checking the above data and sending the data to the service personnel of our company, the service personnel of our company will reply the corresponding solution after receiving the data.

## 9. Battery recovery

Aluminum, copper, lithium, iron and other metal materials are recovered from discarded LiFePO<sub>4</sub> batteries by advanced hydrometallurgical process, and the comprehensive recovery efficiency can reach 80%. The specific process steps are as follows:

### 9.1 Recovery process and steps of cathode materials

Aluminum foil as collector is amphoteric metal. Firstly, it is dissolved in NaOH alkali solution to make aluminum enter the solution in the form of NaAlO<sub>2</sub>. After filtration, the filtrate is neutralized with sulfuric acid solution and precipitated to obtain Al(OH)<sub>3</sub>. When the pH value is above 9.0, most of the aluminum precipitates, and the obtained Al(OH)<sub>3</sub> can reach the level of chemical purity after analysis.

The filter residue is dissolved with sulfuric acid and hydrogen peroxide, so that lithium iron phosphate enters the solution in the form of Fe<sub>2</sub>(SO<sub>4</sub>)<sub>3</sub> and Li<sub>2</sub>SO<sub>4</sub>, and is separated from carbon black and carbon coated on the surface of lithium iron phosphate. After filtration and separation, the pH value of the filtrate is adjusted with NaOH and ammonia water. First, iron is precipitated with Fe(OH)<sub>3</sub>, and the remaining solution is precipitated with saturated Na<sub>2</sub>CO<sub>3</sub> solution at 90 °C.

Since FePO<sub>4</sub> is slightly dissolved in nitric acid, the filter residue is dissolved with nitric acid and hydrogen peroxide, which directly precipitates FePO<sub>4</sub>, separates impurities such as carbon black from acid solution, leaches Fe(OH)<sub>3</sub> from filter residue respectively, and precipitates Li<sub>2</sub>CO<sub>3</sub> with saturated Na<sub>2</sub>CO<sub>3</sub> solution at 90 °C.

### 9.2 Recovery of anode materials

The recovery process of anode materials is relatively simple. After the separation of anode plates, the purity of copper can be more than 99%, which can be used for further refining electrolytic copper.

### 9.3 Recovery of diaphragm

The diaphragm material is mainly harmless, and has no recycling value.

### 9.4 List of recycling equipment:

Automatic dismantling machine, pulverizes, wet gold pool, etc.

# 10. Transportation Requirements

The battery products should be transported after packaging and during the transportation process, severe vibration, impact, or extrusion should be prevented to prevent sun and rain. It can be transported using vehicles such as cars, trains, and ships.

Always check all applicable local, national, and international regulations before transporting a Lithium Iron Phosphate battery.

Transporting an end-of-life, damaged, or recalled battery may, in certain cases, be specially limited or prohibited.

The transport of the Li-Ion battery falls under hazard class UN3480, class 9. For transport over water, air and land, the battery falls within packaging group PI965 Section I.

Use Class 9 Miscellaneous Dangerous Goods and UN Identification labels for transportation of lithium-ion batteries which are assigned Class 9. Refer to relevant transportation documents. Lithium batteries and lithium-ion cells are regulated in the U.S. in accordance with Part 49 of the Code of Federal Regulations, (49 CFR Sections 105-180) of the U.S. Hazardous Materials Regulations.



Figure 10-1: Class 9 Miscellaneous Dangerous Goods and UN Identification Label



